

STEREOSCOPIC MICROSCOPE MBS-10

Maintenance manual

ATTENTION! The microscope design can be somewhat differ from those described in this maintenance manual.

1 PURPOSE

The MBS-10 microscope is intended for observing both three-dimensional and thin-film and transparent objects as well as for performing preparatory operations.

The observation can be performed both in artificial and natural illumination in reflected and transmitted light.

Field of application: botany, biology, medicine, mineralogy, criminalistics, archeology, mechanical engineering, instrument making industry and other fields of science and technology.

2 SPECIFICATIONS

2.1 Magnification, times, in the range	4–100
2.2 Linear field of vision, mm, in the range	39–2.4
2.3 Operating distance, mm, no less	95
2.4 Illumination source	halogen lamp 12V/20W
2.5 Overall dimensions in operating state (disregarding elbow-rest, eyepiece, illuminator), mm, no more: length	265
width	160
height	475
2.6 Mass of device, kg, at most	8
2.7 Mass of device in packing, kg, at most	11

Information of precious and non-ferrous metals content

Aluminum – 4.092 kg

Copper – 0.34 kg

Zinc – 0.053 kg

3 COMPONENTS

3.1 Body with drum	1 pc
3.2 Binocular attachment	1 pc
3.3 Table for operating in reflected light	1 pc
3.4 Table for operating in transmitted light	1 pc
3.5 Power supply unit	1 pc
3.6 Objective $f^* = 90\text{mm}$	1 pc
3.7 Illuminator	1 pc
3.8 Elbow-rest	2 pc

3.9 Lamp-holder (to fix the lamp when operated in reflected light)	1 pc
3.10 Eyepiece 8 ^x	2 pc
3.11 Eyepiece 14 ^x	2 pc
3.12 Eyepiece 8 ^x with scale	1 pc
3.13 Eye shield	2 pc
3.14 Halogen lamp 12V/20W	1 pc
3.15 Light filter	1 pc
3.16 Clump	2 pc
3.17 Preparation glass	1 pc
3.18 Plate	1 pc
3.19 Rubber strap	1 pc
3.20 Flannel cloth	1 pc
3.21 Maintenance manual	1 copy
3.22 Case	1 pc
3.23 Case for spare parts	1 pc
3.24 Packing box	1 pc
3.25 Fused plug VP-1V 1.0 A/250 V	2 pc
3.26 Fused plug VP-1V 3.15 A/250 V	2 pc

4 DESIGN AND OPERATING PRINCIPLE

4.1 Microscope Optical Train

An object image is formed due to the successive rays transmission through the $f^*=90\text{mm}$ objective **16**; pair Galilean systems, set in the drum placed in the body placed in the body **1**; tubules lenses and Schmidt prisms, been in the binocular attachment **5** and changeable eyepieces, which installed into the eyepieces tubes **11** (Figure 1).

Galilean systems are alternatively switched on into the light beam path and allow realizing four versions of the microscope object part magnifications. The fifth version of magnification comes out if the Galilean systems are switched off from the light beam path.

Magnifications values of the objective part of the microscope are given in Table 1.

Table 1 - Magnification of objective part

Linear magnification of Galilean system, mult.	1/3.5	1/2	1	2	3.5
General linear magnification of objective part	0.6	1	2	4	7

The microscope is delivered with two pairs of changeable eyepieces (characteristics are given in Table 2) and eyepiece 8^x with changeable scale and

dioptric setting. The eyepieces are used for observing the image reproduced by the objective part of the microscope. On the eyepieces bodies are indicated the magnifications in round numbers.

Table 2 – Characteristics of changeable eyepieces

Magnification of eyepiece, mult.	Diam. of linear field of vision, mm	Range of output pupil, mm
8	23.0	18.0
14	16.0	16.0

Optical characteristics of the microscope with the use of each pair of the changeable eyepieces and of all the magnifications of the objective part are given in Table 3.

Table 3 - Optical characteristics of the microscope

Characteristics of the microscope	Magnification of eyepiece, mult.		Field of vision in the plane of object, mm	
Magnification of eyepiece, mult.	Magnification of objective part, mult.			
	8	14	8	14
0.6	4.8	8.4	39.6	29.7
1	8.0	14.0	23.0	16.8
2	16.0	28.0	11.2	8.4
4	32.0	56.0	5.6	4.2
7	56.0	100.0	3.2	2.4

Schmidt prisms present a direct image of the object and allow to change the instrument interpupillary distance from 56 to 72 mm depending on the observer's eye.

4.2 Construction

The general view of the microscope is given in Figure 1. The microscope consists of the following basic units:

- optical head;
- microscope table;
- power supply unit.

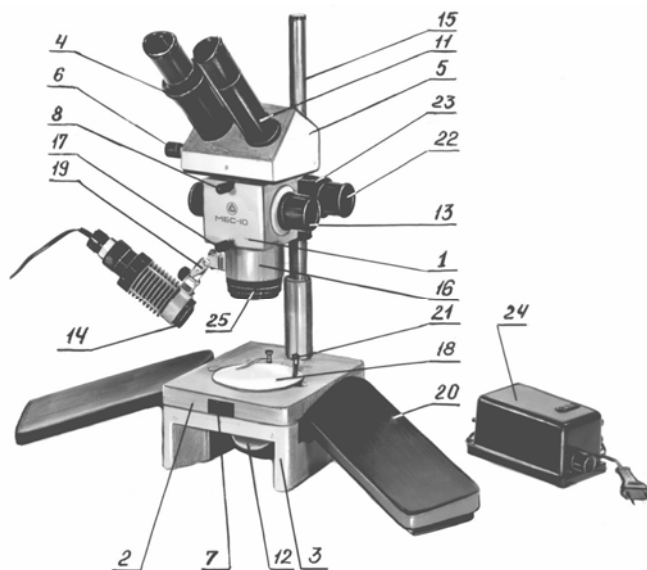

Figure 1 – General view of the microscope

1 – body with drum; 2 – table for operating in reflected light; 3 – table for operating in transmitted light; 4 – dioptic setting ring; 5 – binocular attachment; 6 – handle of interpupillary distance change mechanism; 7 - table lock; 8,17 – screws, fixing the binocular attachment and objective $f^*=90\text{mm}$; 9 – illuminator bush; 10 – illuminator nut; 11 – eyepiece tube; 12 – mirror and clouded glass in mount; 13 – handle of magnification switching; 14 – light filter; 15 – stand; 16 – objective $f^*=90\text{mm}$; 18 – preparation glass; 19 – arm; 20 – elbow-rest; 21 – clamp; 22 – focusing handle; 23 – throw control; 24 – power supply unit; 25 – ring

The optical head consists of the body with the drum, the objective $f^*=90\text{mm}$, the binocular attachment, the illuminator.

The microscope table consists of the table for operating in reflected light and the table for operating in transmitted light.

The necessary magnification is setting by rotation the handle **13** (Figure 1) to match the digit on the handle with the index point on the ring.

The focusing of the microscope on the object is carried out by the optical head traveling relative to the microscope table along the guide line of “dovetail” type by rotation the handles **22** (Figure 1).

ATTENTION! Rotation of focusing handles and magnification change handles in the opposite directions is prohibited.

Throw control of focusing handles from slight to stiff is fulfilled by revolving the handle **23** (Figure 1).

4.2.1 Body with drum

In the body of the optical head incorporates the drum with the Galilean systems. Rotating the handles **13** (Figure 1) which are fixed on the drum shaft changes over the value of magnification. On the handles **13** are indicated the magnifications in round numbers (7, 4, 2, 1 and 0.6 mult.).

4.2.2 Objective $f^*=90\text{mm}$

The objective is fixed to the body of the drum by the bayonet joint. The fixing of the objective is fulfilled by the screw **17**.

ATTENTION! To prevent dropping of the objective the screw **17** should always be screwed against the stop.

4.2.3 Binocular attachment

The objectives and Schmidt prisms are installed in the binocular attachment **5** (Figure 1).

The changing of interpupillary distance is fulfilled by rotation the Schmidt prisms in the opposite direction by the screw mechanism that is put in motion by handle **6** (Figure 1).

ATTENTION! It is absolutely prohibited to change the interpupillary distance by moving the eyepiece tubes toward and apart by hand.

The changeable eyepieces are installed in the eyepiece tubes.

On the left eyepiece tube is a mechanism of dioptric focusing which is fulfilled in the limits of ± 5 diopters by rotation the ring **4**. The diopters nought is installed at the combination of index on the dioptric ring **4** with a mark on eyepiece tube.

The binocular attachment is fixed to the body by the bayonet joint. Its fixing in the seat is fulfilled by the screw **8**.

4.2.4 The microscope table

On the stand **15** of the microscope table is fixed the optical head by the clamping screw which should always be tightened. To prevent an accident dropping of the optical head and for improvement of illumination in the right and left branches of the microscope on the stand is a clip **28** (Figure 2), fixed in the required position by screw **26** (Figure 2). The table has a round window (see Figure 1), in which the preparation glass or the plate **18**, two holes for the clamp **21** and three holes for the substage ST-12 setting are installed, the latter is

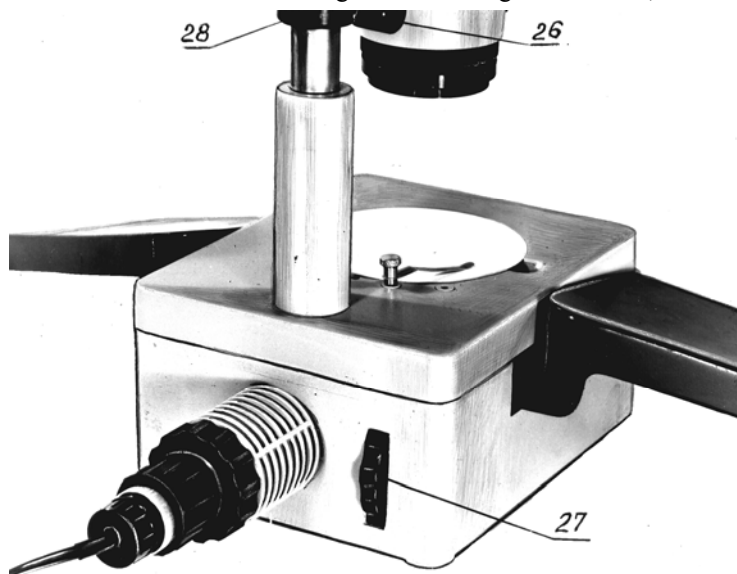

Figure 2 – The microscope table

not included in the microscope standard equipment and is purchased separately. The one side of the plate **18** is white and is intended for observing dark objects, the other side is black and is intended for observing light objects. The table **2** for operating in reflected light is mounted on the table **3** for operating in transmitted light and is fixed by the lock **7**, faced to the front open side of the table body. There are mirror and clouded plate in mount **12** in the table **3**. Their rotation is fulfilled by knob **27** (Figure 2). The table rear wall has a seat for fixing the illuminator in operating with reflected light. The side walls of the table have seats for mounting the elbow-rests.

4.2.5 Illuminator

If operating at reflected light the illuminator is installed in the arm seat **19** (Figure 1) which makes possible to illuminate the object under different angles and from different sides. The arm **19** can be fixed in the required position by rotation the ring **25**.

The disassembled illuminator is represented in Figure 3 and consists of the lamp **1**, the body **2**, the seat flange **3**, the chuck **4**, the spring **5**, the flex **6**, and the bush **7**.

The microscope equipment has a light filter that is united through the thread to the seat flange **3** of the illuminator.

The illuminator power can be controlled changing lamp power voltage.

8

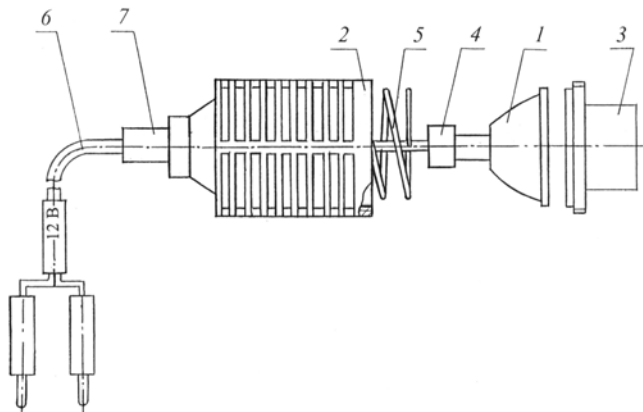

Figure 3 – Illuminator

When replacing the lamp it is necessary, keeping safety precautions listed in the paragraph 5.3, to weaken the flex **6** fixing (see Figure 3) by the bush **7** (counterclockwise rotation), screw the seat flange **3** out, remove the flex with the lamp **1** and with the chuck **4** out of the body **2**, replace the lamp in the chuck. The assembling should be made vice versa.

4.2.6 Power supply unit

The power of the illuminator lamp is provided through the power supply unit **24** (Figure 1) from alternating current mains of 220 V using the flex with the plug of the side ground contact. The cover of the power supply unit has a connector of 12V for the illuminator switching on (by means of two prongs). The side walls of the power supply unit have toggle switch, lamp voltage regulator, holders of safety devices (of fused plugs) of 1.0A and 3.15A.

5 SAFETY PRECAUTIONS

5.1 The instrument is intended for indoor operation under conditions of absence of increased electrical danger. The conditions increasing the mentioned danger are:

- a) increased humidity and dustiness of air;
- b) current-conducting floor: metal, brick, reinforced-concrete;
- c) temperatures above 40⁰C.

5.2 Regularly, before connecting the instrument to the power mains, the safety of the cord insulation, power supply unit and illuminator should be checked.

5.3 The lamp and fused plugs (safety devices) removing is required to make under de-energized illuminator and power supply unit.

6 PREPARATIONS FOR USE

If the instrument is delivered indoors from cold, unpack it six hours after bringing it inside.

After unpacking the instrument is needed to be prepared for the operating for which is purpose:

- a) install the body with the drum on the stand **15** and tighten the screw;
- b) install the binocular attachment in the bayonet seat of the body with drum and tighten screw **8**. In operating with artificial lighting the binocular attachment **5** should be installed as it is shown in Figure 1. At the natural lighting it is necessary to rotate the binocular attachment at 180° ;
- c) install the objective $f^{\circ}=90\text{mm}$ and tighten screw **17**;
- d) install the lamp in the lamp holder of illuminator and adjust illumination as instructed in paragraph 4.2.5;
- e) choose the pair of eyepieces of required magnification (see Table 2);
- f) install the eye shield that is included in the microscope standard equipment;
- g) check up the correspondence of magnification to the reading on the handle **13**. Proceed as follows:

- 1 Take the binocular attachment **5** off.

- 2 Install the drum so that through the seat under the binocular attachment should be seen the apertures in the drum without optics and at both sides of these apertures should be seen the mounts with the small optics of the drum.

- 3 The index on the ring must coincide with figure 2 at the handle of the drum that is between 7 and 4. If index don't coincide with the indicated figure, return the ring with the index around its axis to combine with the indicated figure 2.

7 OPERATION PROCEDURE

7.1 General Indication

Focus the microscope on the object by rotation the handle **22** (Figure1). Install the interpupillary distance according to the base of observer's eye, by turning the handle **6**.

When operating at the large magnifications use the handle of throw control **23** at the focusing on the object. Choose the position of illuminator by turning it with the arm about the objective and choose the handy angle of slope.

The dioptric focusing must be used after the microscope has been focus on the object on the right branch that doesn't have the dioptric focusing.

7.2 Operation with Eyepiece 8^{\times} with the Scale

The eyepiece has a mechanism of dioptric setting. The scale is set in the focal plane; grid, which is delivered under the special order, can be set instead of the scale. The name of grid for special order “Grid in box. IAZU. 305648.010” The scale and the grid are actually plane-parallel glass round plates. The scale division value is 0.1mm; the grid square side value is 1.0mm

To perform linear measurements or measurements of various object areas, insert the eyepiece 8^x with the scale into the one of the eyepiece tubes of the microscope. By the mechanism of dioptric setting of the eyepiece obtain a sharp image of the scale or the grid (depending on what is installed). Then, rotating the knob of the focusing mechanism obtain the sharp image of the object. The table 4 shows to what actual value of the object corresponds one division of the scale or the grid at all values of magnification of the microscope.

Table 4 - Conversion table of the microscope magnifications

Magnifications in round numbers on the handles of the drum, mult.	Scale one division, 0.1mm	Square side, 1mm
	Corresponds to actual value of the object	
0.6	0.17	1.7
1	0.1	1.0
2	0.05	0.5
4	0.025	0.25
7	0.014	0.14

In order to determine the approximate dimensions of the object (its linear dimensions or area) it will suffice to count the number of the division of the scale which are laid in the measured section of the object and to multiply the obtained result by the number indicated in the conversion. Table corresponding to the magnification of the microscope at which the measurement is being performed.

To replace the scale (or the grid), proceed as follows:

- 1 turn the scale rim out of the eyepiece body. The rim is found in the bottom part of the eyepiece;
- 2 turn out the nut fastening the scale (or the grid) and remove carefully the scale from the rim;
- 3 install the grid into the rim and tighten up the nut;
- 4 turn the rim into the body of eyepiece.

8. MAINTENANCE

When receiving the microscope pay attention if the Manufacturer’s seal is intact.

The microscope leaves the Manufacturer duly tested and can operate free of trouble for a long time, provided it is kept clean, properly cared of and

prevented from any kind of mechanical damage. The Manufacturer's package ensures safety of the microscope during its transportation. When not using, the microscope should be covered by the case.

To keep the microscope good appearance, it should be wiped periodically, excepting optical surface, by a soft cloth impregnated by acid-free vaseline after which the instrument should be dried by a soft clean cloth.

If after a certain time the grease in the focusing mechanism guides becomes dirty and thick, remove it by using xylene or benzene, wipe the friction surfaces with a clean soft cloth and greasy slightly the guides with the acid-free vaseline or special grease. Pay special attention to the cleanness of the microscope optical elements. During the operation the optical surface has to be prevented from moisture.

To prevent the prisms surfaces from dust, the eyepieces should be always left in the eyepieces tubes of the microscope. The eyepieces have to be also prevented from dust.

The lenses surfaces should not be touched by fingers and hard objects in order to avoid a spoilage of coated surfaces.

When cleaning the lenses surfaces, dust and other soiling should be removed by using a soft clean cloth. If after that the optical surfaces are insufficiently clean, use a soft batiste cloth slightly moistened by spirit.

9 ACCEPTANCE CERTIFICATE

The MBS-10 microscope, serial No _____
meets the technical specifications and has been found fit for service.

QCD Representative

«__» _____ 200

10 PRESERVATION AND PACKING REPORT

The MBS-10 stereoscopic microscope, serial No _____
has been subjected to preservation treatment and duly packed at the
Manufacturing factory in compliance with the requirements prescribed by the
technical documentation.

Preserved and packed on _____

Preservation and packing were made by _____

295-03

STEREOSCOPIC MICROSCOPE MBS-10

Maintenance manual